

SERIES CO6 AND CO12

● FEATURES

- STANDARD 8 AND 14 PIN DIP PACKAGE
- TOLERANCE AND STABILITY TO ± 25 PPM
- EXCELLENT CLOCK FOR 16 AND 32 BIT PROCESSORS
- LOW COST
- AVAILABLE IN 3.3 VOLT

● SPECIFICATIONS

SERIES		CO6	CO12
PACKAGE		14 PIN DIP	8 PIN DIP
FREQUENCY RANGE		500.00 KHz TO 125.00 MHz	500.00 KHz TO 125.00 MHz
FREQUENCY STABILITY†		CO6100 : ± 100 PPM	CO12100 : ± 100 PPM
		CO6050 : ± 50 PPM	CO12050 : ± 50 PPM
		CO6025 : ± 25 PPM	CO12025 : ± 25 PPM
OPERATING TEMPERATURE RANGE		0° C TO +70° C STANDARD -40° C TO 85° C EXTENDED	0° C TO +70° C STANDARD -40° C TO 85° C EXTENDED
STORAGE TEMPERATURE RANGE		-55° C TO +125° C	-55° C TO +125° C
INPUT	VOLTAGE††	+5 VDC ± 0.5 VDC	+5 VDC ± 0.5 VDC
	CURRENT (MAX)	500 KHz TO 19.999 MHz: 20 mA	500 KHz TO 19.999 MHz: 20 mA
		20 MHz TO 34.999 MHz: 30 mA	20 MHz TO 34.999 MHz: 30 mA
		35 MHz TO 69.999 MHz: 40 mA	35 MHz TO 69.999 MHz: 40 mA
70 MHz TO 125 MHz: 60 mA		70 MHz TO 125 MHz: 60 mA	
OUTPUT	SYMMETRY	40 TO 60% NORMAL 45 TO 55% TIGHT	40 TO 60% NORMAL 45 TO 55% TIGHT
	RISE AND FALL TIME (0.5 - 4.5 VDC)	UNDER 24 MHz : ± 10 ns MAX	UNDER 24 MHz : ± 10 ns MAX
		24 MHz TO 70 MHz : ± 6 ns MAX	24 MHz TO 70 MHz : ± 6 ns MAX
		70 MHz TO 125 MHz : ± 3 ns MAX	70 MHz TO 125 MHz : ± 3 ns MAX
	LOGIC "0" LEVEL	+0.5 V MAX. (10% VDD)	+0.5 V MAX. (10% VDD)
	LOGIC "1" LEVEL	+4.5 V MIN (90% VDD)	+4.5 V MIN (90% VDD)
LOAD†††	15 pF OR 10 LS TTL STANDARD	15 pF OR 10 LS TTL STANDARD	

† FREQUENCY STABILITY INCLUSIVE OF ROOM TOLERANCE, FREQUENCY STABILITY OVER TEMPERATURE, 10% POWER SUPPLY VARIATION, AGING, SHOCK, AND VIBRATION

†† +3.3 VOLT VERSION IS AVAILABLE. CONSULT RAMI FOR SPECIFICATIONS

††† OUTPUT LOADS ALSO AVAILABLE AT 15 pF, 30 pF AND 50 pF. CONSULT RAMI FOR SPECIFICATIONS

● ENVIRONMENTAL AND TECHNICAL CONDITIONS

ENVIRONMENTAL	
TEMPERATURE CYCLE	MIL-STD 883, METHOD 1010, 10 CYCLES -20° C TO 85° C
SHOCK	MIL-STD-202, METHOD 213, TEST CONDITION C
VIBRATION	MIL-STD-202, METHOD 204, TEST CONDITION A
RESISTANCE TO SOLDERING HEAT	MIL-STD-202, METHOD 210, TEST CONDITION B
HUMIDITY	85% RELATIVE HUMIDITY AT 85° C 250 HOURS
MECHANICAL	
GROSS LEAK TEST	MIL-STD-883, METHOD 1014, TEST CONDITION C
FINE LEAK TEST	MIL-STD-883, METHOD 1014, TEST CONDITION A
TERMINAL STRENGTH	MIL-STD-202, METHOD 211, TEST CONDITION A AND C
MARKING INK	EPOXY, HEAT CURED.
MOISTURE RESISTANCE	MIL-STD 202, METHOD 106, OMIT STEP 7B
SOLDERABILITY	MIL-STD-202, METHOD 208, 95% COVERAGE
SOLVENT RESISTANCE	MIL-STD-202, METHOD 2002, METHOD 215

● OUTPUT WAVEFORMS

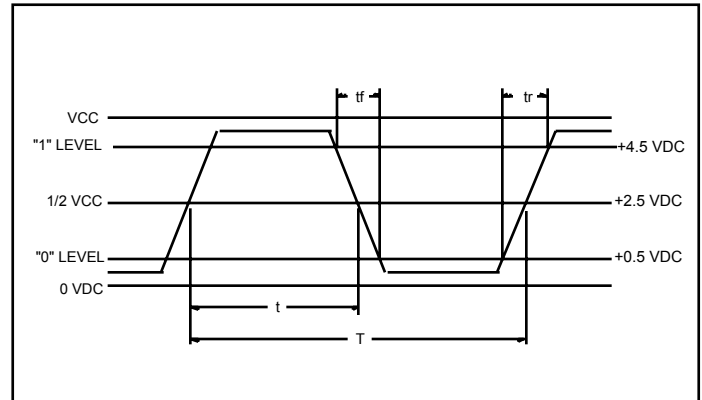

● PART NUMBERING SYSTEM

SERIES		FREQUENCY STABILITY		FREQUENCY	EXTENDED TEMPERATURE	SYMMETRY		OPTIONS				
CO6	(14 PIN DIP)	100	± 100 PPM	-	-	-	T	TIGHT SYMMETRY	TR	TAPE AND REEL*		
CO12	(8 PIN DIP)	050	± 50 PPM						IN MHz	EXT	GW	GULL WING
		025	± 25 PPM								3.3	+3.3 V

EXAMPLE: CO6100-10.000-EXT-T, CO12050-32.000-EXT-T-TR

* Available for Gull Wing only

● TEST CIRCUIT

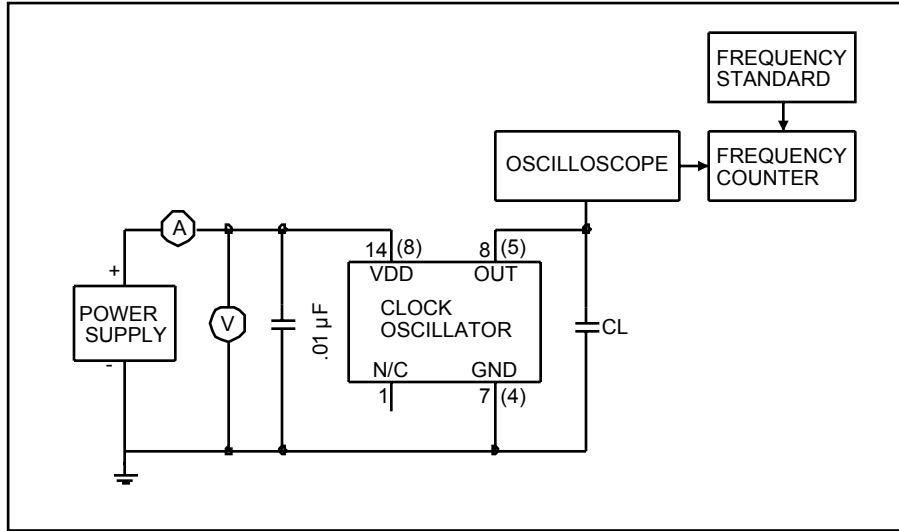

● DIMENSIONS

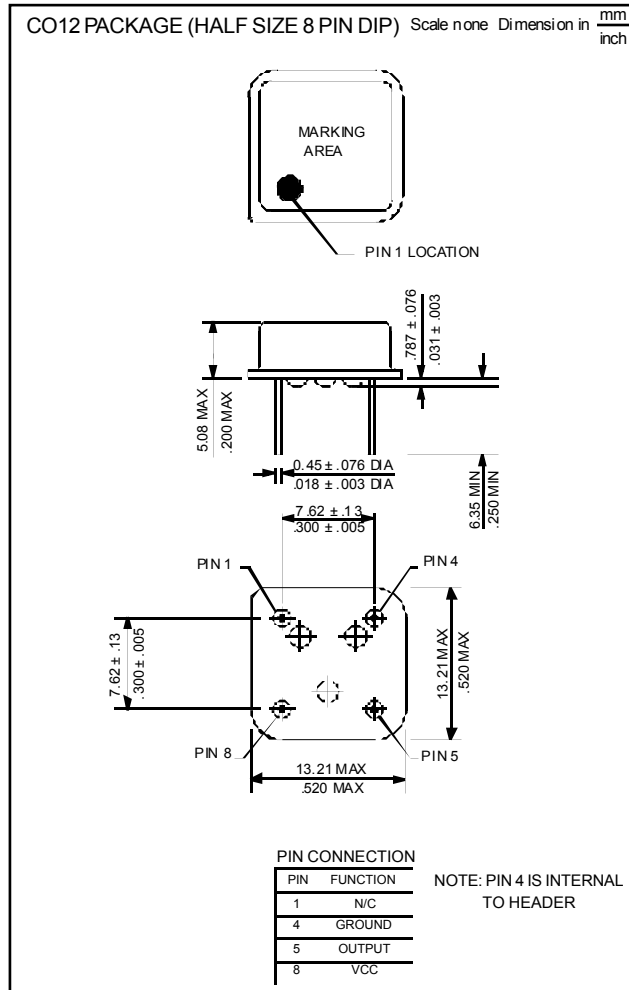
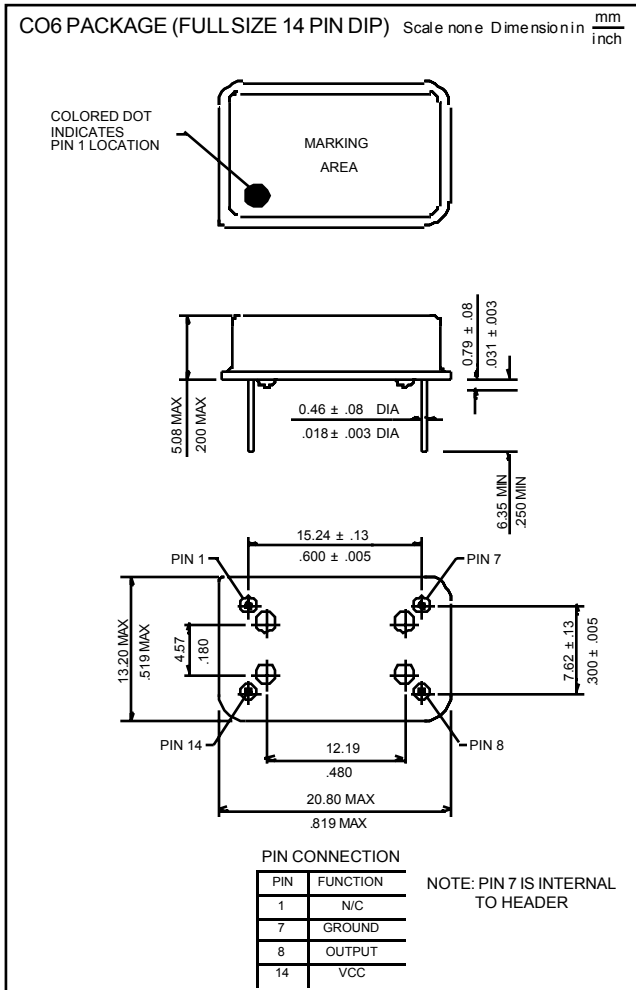

● PACKAGING

14 PIN DIP: 25 PIECES PER ELECTROSTATIC TUBE
8 PIN DIP: 40 PIECES PER ELECTROSTATIC TUBE