

SERIES RSE H14

● FEATURES

- SUITABLE FOR TIME OF DAY CLOCK APPLICATIONS
- LOW PROFILE 1.3 mm HEIGHT
- EXCELLENT FOR AUTOMATIC AND HIGH DENSITY SURFACE MOUNTING

● SPECIFICATIONS

NOMINAL FREQUENCY	32.768 kHz
FREQUENCY TOLERANCE	±20 PPM, ±50 PPM
TURNOVER TEMPERATURE	±25°C ±5°C
TEMPERATURE COEFFICIENT	-(0.035±0.01) PPM/°C ²
LOAD CAPACITANCE	12.5 pF
EQUIVALENT SERIES RESISTANCE	65 KOHMS MAXIMUM
DRIVE LEVEL	0.1 μW TYP, 1 μW MAX.
SHUNT CAPACITANCE	0.8 pF TYPICAL
AGING (FIRST YEAR)	±3 PPM/YEAR MAXIMUM
OPERATING TEMPERATURE RANGE	-20°C TO +70°C
STORAGE TEMPERATURE RANGE	-40°C TO +125°C
INSULATION RESISTANCE	500 MOHMS MINIMUM
SHOCK RESISTANCE	±5 PPM MAXIMUM



● OUTLINE DRAWING

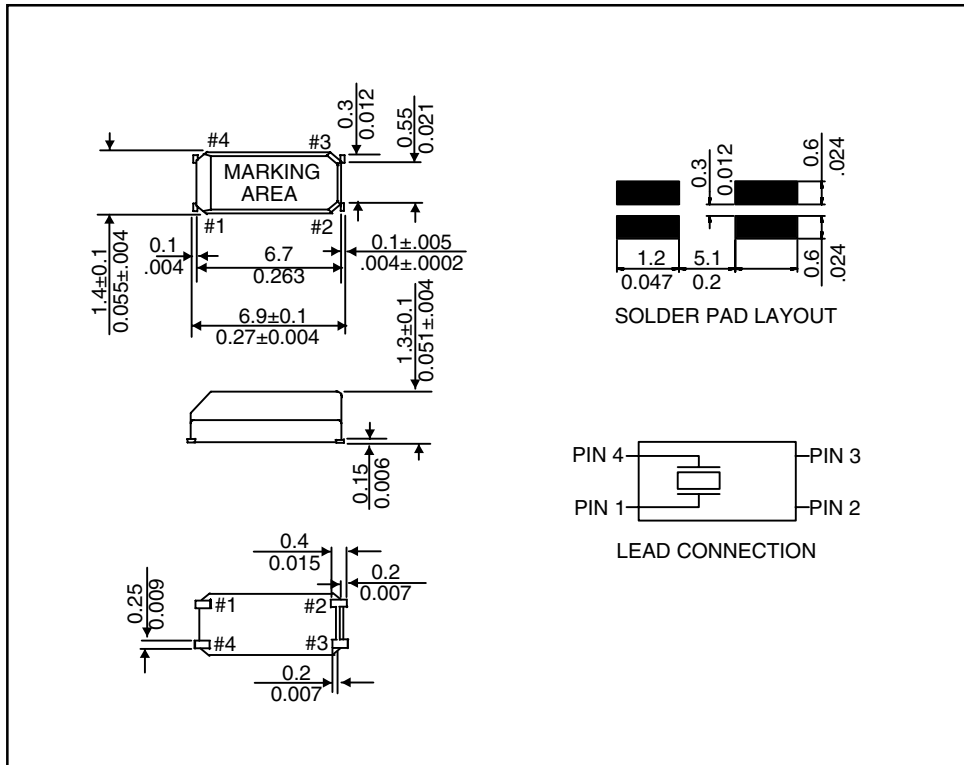

● CARRIER TAPE DIMENSIONS

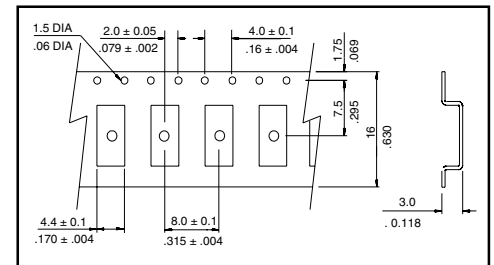

● REFLOW SOLDERING PROFILE

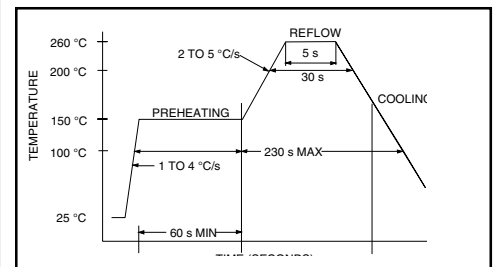

● FREQUENCY VS. TEMPERATURE CURVE

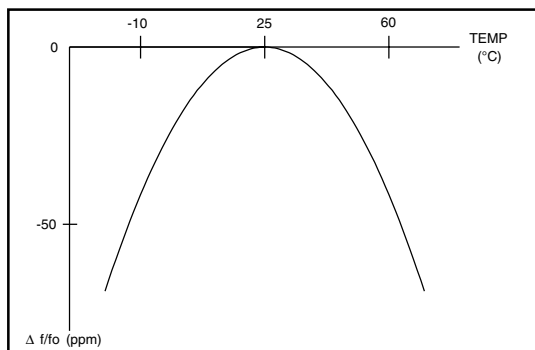

● PACKAGING

- 330mm REEL DIAMETER
- 16mm TAPE WIDTH, 8mm PITCH
- QUANTITY: 3000 PIECES PER REEL

● PART NUMBERING SYSTEM

HOLDER TYPE	FREQUENCY	LOAD CAPACITANCE	H14	TAPE & REEL
RSE	IN kHz	12.5 pF		TR

EXAMPLE: RSE-32.768-12.5-H14-TR