

## OCXO SERIES 9400

### ■ FEATURES

Excellent frequency stability  
 High Frequency up to 100MHz  
 Low Profile

### APPLICATIONS

- TELECOM  
 - BASE STATION  
 - INSTRUMENTATION

### ■ ELECTRICAL PERFORMANCE

PARAMETER	OCXO SERIES 9400	
	AT CUT CRYSTAL	SC CUT CRYSTAL
Supply voltage, nom.	12V, 5V, 3.3V $\pm 5\%$ Standard	
Power dissipation steady state	2 Watt Max.	
Heat up power	5 Watt Max.	
Heat up time.	5 min Max	
Frequency range	10 To 100MHz Standard	
Frequency Adjustment: Electrical (0 to 5V) Electrical (0 to 10V)	$\pm 10$ PPM Min $\pm 15$ PPM Min	$\pm 0.7$ PPM Min $\pm 1$ PPM Min
Freq. stability vs. temperature LX: 0°C to 60°C FZ: -30°C to 70°C	$\pm 0.05$ PPM $\pm 0.15$ PPM	$\pm 0.010$ PPM $\pm 0.020$ PPM
	(Standard, contact factory for different temp ranges and stabilities)	
Freq. stability vs. supply changes	$\pm 0.01$ PPM Max for $\pm 5\%$ Change	$\pm 0.005$ PPM Max for $\pm 5\%$ Change
Freq. stability vs. load changes	$\pm 0.005$ PPM Max for $\pm 5\%$ Change	$\pm 0.002$ PPM Max for $\pm 5\%$ Change
Long term stability (Aging)	$\pm 0.5$ PPM Max for 1 Years $\pm 0.005$ PPM/Day Max.	$\pm 0.1$ PPM Max for 1 Years $\pm 0.002$ PPM/Day Max.
Output	HCMOS/TTL/Sine 0 to +10dBm	
Harmonics, Sub Harmonics	-30dBc(Sine Output)	
Spurious	-75dBc(Sine Output)	
Duty cycle	40/60% to 60/40%(HCMOS)	
Rise / fall time	10nS Max. (HCMOS, 10%~90%Vout, 90%~10%Vout)	
Short term Stability (10MHz)	1 E-10 /Sec	5 E-11 /Sec
Phase Noise typical under static conditions (Sine Output 10MHZ)	Offset      Phase Noise 10Hz      -95 dBc/Hz 100Hz     -125 dBc/Hz 1000Hz   -135 dBc/Hz 10000Hz  -150 dBc/Hz	Offset      Phase Noise 10Hz      -115 dBc/Hz 100Hz     -135 dBc/Hz 1000Hz   -145 dBc/Hz 10000Hz  -150 dBc/Hz

Note: All Typical parameters for a 10MHz output and 5V Supply, for different frequencies consult factory

## ■ HOW TO ORDER (PART NUMBER)

Prefix	Output Type	Cut Type	Series	Revision	Temperature Range	Stability	Frequency	Supply Voltage
OX	1:TTL 2:HCMOS 3:ACMOS 4:LVCMS 6:SINE	0:AT (No Vcontrol ) 1: SC (No Vcontrol ) 4: AT (Elect Vcontrol) 5: SC (Elect Vcontrol)	94: 9400	A	First letter Lowest Temperature, Second letter Highest Temperature: From A=-55°C to Z=+70°C, Then: 1=+75°C, 2=+80°C, 3=+85°C... in 5°C steps Example: LZ: +0°C to +70°C LX: +0°C to +60°C FZ: -30°C to +70°C D3: -40°C to +85°C	Value x 10E-2 in PPM  Example  28= 0.28PPM  10= 0.1PPM	In MHZ	3.3; 3.3V  5: 5.0V 12; 12V

Example:

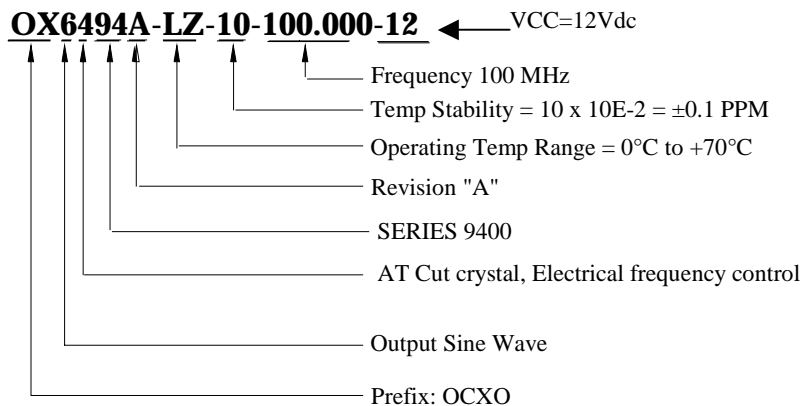

## ■ MECHANICAL SPECIFICATION

