

SY02-MFTC

Date: Aug 4,2005

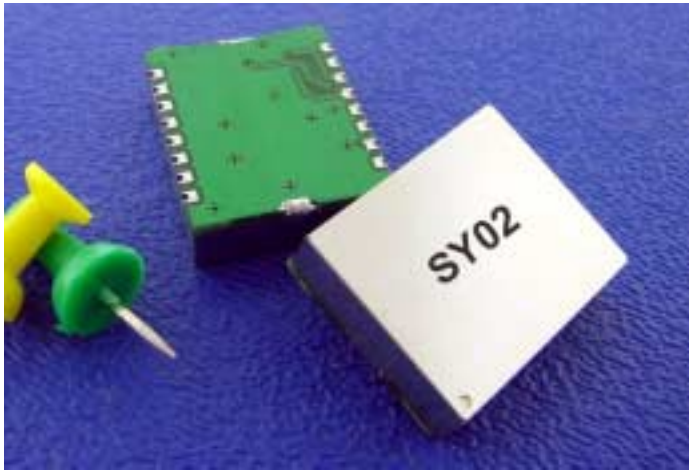

- **INTRODUCTION**

The SY02-MFTC is a high frequency crystal-based PLL synchronizer designed as a module level subsystem for easy incorporation into telecommunication equipment SONET/SDH/ATM/DWDM. Supports multiplexing of up to 4 independent references translated into one single jitter free frequency source.

- **FEATURES**

- Low jitter output from intrinsically low jitter VCXO ;
- User Selected one LVCMOS/HCMOS Input frequency **Up to 77.76MHz**
- One frequency LVCMOS/HCMOS output with enable/disable function **Up to 77.76MHz** (pre-select frequency value – upon order)
- Alarms status and VCXO monitor;
- The unit changes timing modes in response to external events;
- J-TAG service port for re-programming and servicing;
- 3.3V DC power supply
- Small dimensions: 0.8" x 1.00"

- **APPLICATIONS**

- ATM
- SDH
- PDH
- SONET
- DWDM
- FEC
- Other telecommunication equipment.

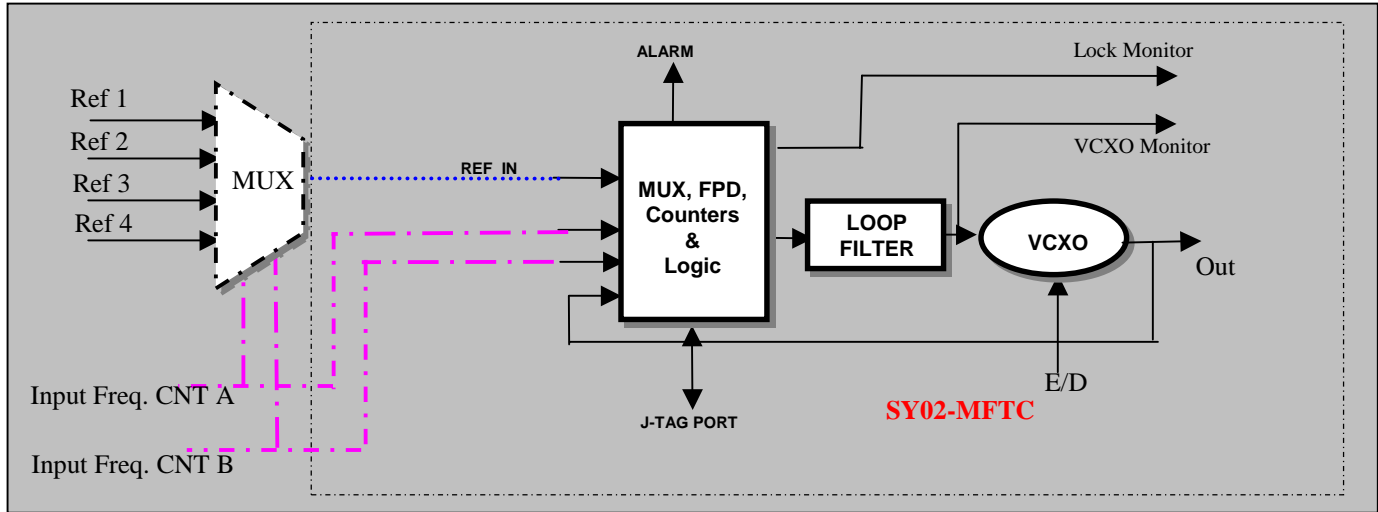

Figure 1 – Block Diagram (**Components outside the dotted line are user supplied)

• **DESCRIPTION**

The SY02-MFTC is a High Frequency Phase Lock Loop has been designed as a module level subsystem for easy incorporation into telecommunication equipment. The module generates the high frequency (up to 200MHz) output from a low jitter VCXO (Crystal Based Oscillator. The output can be disabled externally by setting OUTEN pin high. The SY02-MFTC can be locked to a user defined input reference signal **(from 8KHz to 77.76MHz...for options please see table)**.

Frequency selection could be simultaneously achieved of up to 4 independent sources while combining the module with an external MUX. RAMI's SY02-MFTC device could be used as a frequency translator in PLL circuits or frequency regenerator device in cases where jitter cleaning and filtering is required. The module has a fast locking time and tolerates reference inputs with different duty cycles. The loop bandwidth is optimized in accordance with the VCXO used and

required output performance. The ALARM output signals monitor the status of the phase lock loop and indicates LOL (Loss of Lock Detect). If the reference REF IN is absent, the SY02-MFTC will automatically switch to free run mode and LOL will show "0" logic level. The SMD package dimensions are 0.80"x1.00" inch and powered by a supply of 3.3V.

➤ ALARM STATES

LOLD	ALARM
0	Module in Free-run
1	Module locked

➤ Input Reference Control select

CNT A	CNT B	Selected Option
0	0	EXT Ref 1
0	1	EXT Ref 2
1	0	EXT Ref 3
1	1	EXT Ref 4

● **PIN DESCRIPTION**

	Name	Description	Signal Technology	VL			VH/ DC Voltage		
				Min	Typ	Max	Min	Typ	Max
1	Ref In	Input Reference Signal	HCMOS (3.3 Tolerable)	0	----	0.3	2.97	----	----
2	GND	Ground	----	----	----	----	----	----	----
3	LOL	Lock Detect Alarm out – High when locked; Low when unlocked	DC	0	0.15	0.3	2.97	3.3	3.465
4	MNTR	VCXO Monitor out- DC control voltage offset indicator (when locked shall be within); 0.3<Vmntr<3.0 (for 3.3V supply)	DC	0	0.15	0.3	2.97	3.3	3.465
6	N/C	No Connect	----	----	----	----	----	----	----
7	GND	Ground	----	----	----	----	----	----	----
8	Enable/Disable	Output Enable - > enables the output, active low ("0" logic) or floating Disables the output, active high ("1" logic)	DC	0	0.15	0.3	2.97	3.3	3.465
9	OUT	Oscillator Output -> Output of the module	HCMOS (3.3 Tolerable)	0	----	0.3	2.97	----	----
10	GND	Ground	----	----	----	----	----	----	----
11	N/C	No Connect	----	----	----	----	----	----	----
12	CNT A	Frequency Select; See Table page 2.	DC	0	0.15	0.3	2.97	3.3	3.465
13	CNT B	Frequency Select; See Table page 2.	DC	0	0.15	0.3	2.97	3.3	3.465
14	N/C	No Connect	----	----	----	----	----	----	----
15	GND	Ground	----	----	----	----	----	----	----
16	Vcc	Positive supply voltage	DC – 3.3V	----	----	----	2.97	3.3	3.465

● **ORDERING INFORMATION**

- Input/Output Frequencies available;

Frequency	Suffix	Frequency	Suffix
8KHz	F8	20.4800MHz	A4
1.024MHz	E0	22.2171MHz	A5
1.544MHz	T1	26.0000MHz	G3
2.048MHz	E1	27.0000MHz	A6
4.096MHz	E2	29.4912MHz	A7
6.1760MHz	T2	32.768MHz	E5
6.480MHz	D1	34.560MHz	A8
8.192MHz	E3	37.0560MHz	A9
10.000MHz	A1	38.880MHz	O2
12.800MHz	S1	44.4343MHz	B1
13.000MHz	G1	44.7360MHz	T3
15.000MHz	A2	51.8400MHz	D2
16.384MHz	E4	61.4400MHz	U1
19.440MHz	O1	62.5000MHz	G5
20.000MHz	M1	65.5360MHz	B2
20.1416MHz	A3	77.7600MHz	O3
37.0560MHz	A9		

➤ **P/N System**

RAMI TECHNOLOGY 10651 NW 19th St. Miami, Florida 33172 U.S.A. Tel: 305-593-8000
Fax: 305-593-8487 e-mail: sales@ramitechnology.com web: www.ramitechnology.com

SY02-MFTC – IP < Input Frequency> - OU<Output Frequency>-S-T<Temp. Range>

➤ See above Chart (If not listed Place **NL** and state the Freq.)

➤ See above Chart (If Output Freq. Not applied place **NA** and state the Freq.)

➤ Supply Voltage;
4 – 3.3V

➤ Operating Temperature Range;
C - 0°C to 70°C
I - -40°C to +85°C

• **SPECIFICATION**

General Specifications	Mechanical	1.000" x 0.800"x0.235"	SMT Module FR4 16 pins dual-in-line
	Power Environment	3.3VDC +/-5%, <200mA Operating Temperature Humidity	Regulated 0°C to 70°C or -40°C to +85°C 5% to 95% non-condensing Depends on the frequency
	Internal Oscillators	VCXO or VCXO	
Input Signals	Number of Reference Inputs	1	Up to 4 selectettable with an external MUX
	Input reference frequency Signal Level	Per selected table on page 3 HCMOS (3.3 V tolerable)	(other input frequencies available)
Output Signals	Number of Outputs	1	
	Output 1	Per selected table on page 3	other frequency contact RAMI
	Output 1 Signal Level	HCMOS/LVCMOS	
	Duty Cycle	50+/-10%	50%+/-5% available upon request
	Tracking/Capture Range	±50ppm APR min	
Signal Quality Performance	Jitter generation	<0.001UI RMS <0.001UI RMS <0.0001 UI RMS <0.0001 UI RMS	HPF 30Hz HPF 500Hz HPF 12KHz HPF 100KHz
	Jitter attenuation	-40dB -10dB	Fj=10Hz~1KHz Fj=1KHz~10MHz
	Jitter tolerance	2 μs, 10 Hz (0.05 UI @ 8KHz)	

- REFLOW PROFILE

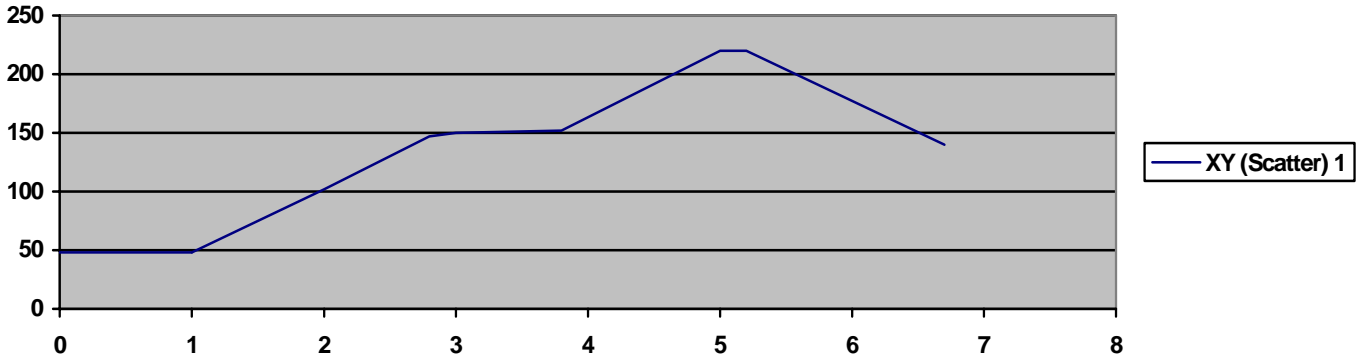

- OUTLINE DRAWING

